

# UG PEDESTAL SERVICE INSTALLATION

2" thick treated lumber. All wood materials must be new pressure treated and suitable for burial. Painted surfaces not acceptable. Area must be large enough to mount the necessary equipment.

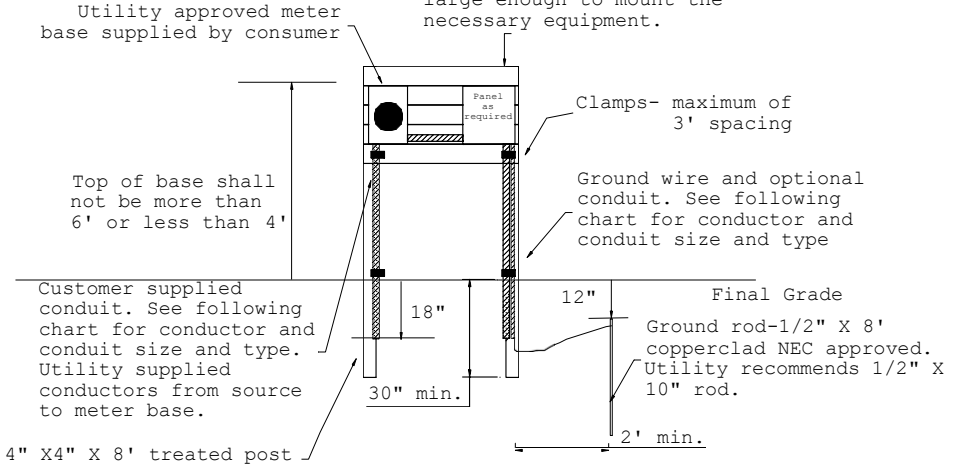

# RESIDENTIAL UG SERVICE REQUIREMENTS

Service	Schedule 80 PVC Riser Min. Diameter	Entrance Cable Min. Size		Ground Wire Min. Size	EMT or PVC Ground Wire Riser Min. Size
		CU.	AL		
Loop Size		CU.	AL	CU	
200 A	2"	2/0	4/0	#4	1/2"
400 A	3"	400 MCM	600 MCM	#2	1/2"
600 A	4"	1000 MCM		2/0	1"

- **Notes**

1. Aluminum not allowed by all local building authorities.
2. All metal conduits must have plastic bushings at each end.
3. Use treated wood only for built meter pedestals.
4. Use 4"x4"x8' or larger treated wood posts.
5. All meter sockets installed on the REMC's system shall comply with U.L. 486B, U.L. 414, NEMA 250, and ANSI-C12.7 standards.
6. Outside disconnects must be raintight.
7. Conduit and ground rod to extend below ground level as noted on drawing.
8. Threaded adapters, locknuts, and bushings installed on all conduits and sleeves at enclosures as shown.
9. Utility with jurisdiction supplied material.
  - a. Meter
  - b. Service wire installed by REMC from transformer to the top side of the meter base.
10. For services 50KVA or greater, owner must provide proof that the AIC (Ampere Interrupting Capacity) rating of panel, main and sub breakers exceeds the available short circuit current. Short circuit current information can be obtained from SCI Engineering. SCI requires that 50KVA or greater services carry labels displaying the equipment AIC.

<b>UNDERGROUND SERVICE INSTALLATION NOTES</b>
---

1. Ground wire installed in metal conduit, must be bonded at both ends to grounding conductor. Service may be grounded at panel or meter base but not both. Install ground rod and attach ground wire to rod with a one-bolt ground rod clamp (water pipe clamps not acceptable). *Reference local requirements for ground rod installation.*
2. It shall be the customers responsibility to maintain a clear path, 15 feet in width, from the source of power to the meter base. This route must be within 6 inches of final grade.
3. It shall be the customer's responsibility to locate and expose consumer underground electrical wires, septic lines, field tile, water lines, or any other underground facility that may be damaged during trenching, that are in the service route.
4. Where the service will pass under a driveway, patio, or sidewalk install a minimum of schedule 40 electrical conduit, with pull wire, to extend 5 feet on either side. Place stakes at each end of the conduit.
5. Where the end of the service riser conduit will be in concrete, install a schedule 80 service riser conduit, with a minimum schedule 40, 90 degree long sweeping elbow and a piece of minimum schedule 40 conduit extending past the concrete. This is to be installed under the concrete. Install a pull wire in the conduit and place a stake at the outside end of the conduit.
6. Conduit for service wires entering the bottom of the meter base will be installed in the left or right side knockout. Do not use center bottom knockout.
7. Customer will refrain from digging or planting trees and shrubbery that would interfere with underground equipment or would make it difficult to open the trench for servicing the cable.
8. Utility will backfill the trench at the time of installation. ANY FUTURE BACKFILL NEEDED WILL BE THE RESPONSIBILITY OF THE CUSTOMER.